

### Features and Benefits:

- Minimize clogging of print head and glue nozzles
- Extend bearing life
- Reduce downtime for cleanup
- Eliminate "clumps" that either cause web breaks or product defects
- Increase production line efficiency
- Reduce operator exposure to dust.

### Industries:

Textiles, paper, tobacco, wood, plastics, agricultural & rubber dust applications.

### Available Services:

- System Integration
- Industrial Ventilation
- Material Handling
- Power & Controls
- Manufacturing

### Product Description:

ATMOS360'S Web Cleaning System is applicable from very weak to strong web handling processes. Initially developed for the cleaning of fragile (soft bathroom) tissue webs, this system can be applied to a wide variety of film, fiber and textile webs. ATMOS360's web cleaning system is ideal for achieving a clean surface prior to rewinding, printing, gluing or final packaging.

Web cleaning removes dust from the product surface and can minimize production losses due to dust build-up in the converting equipment. Reduced fugitive dust on and around converting equipment can lead to operational and maintenance savings.

Our Web Cleaning System comes complete with a self-contained blower with inlet air filter; compressed air is not required with this web cleaning system. Static elimination may be incorporated if appropriate. The upper cleaning hood can be pneumatically actuated to swing away and enhance machine thread up efficiency or allow other maintenance activities. The integral dust capture hood may be ducted to your existing dust collector if capacity exists, or we can provide a dust control collector or complete system.

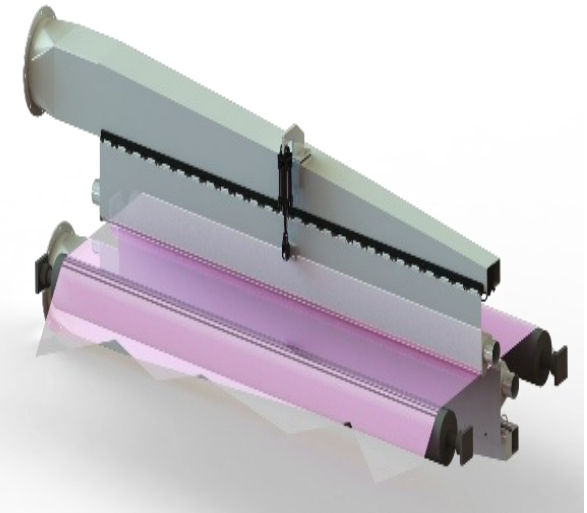

### *WEB CLEANING COLLECTION SYSTEM*

**64 CIRCLE FREEWAY DR  
CINCINNATI, OH 45246**

**[www.atmos360.com](http://www.atmos360.com)**

**Phone: 513-330-5442**

**E-mail: [info@atmos360.com](mailto:info@atmos360.com)**

# ATMOS360 Custom Engineered Industrial Air Filtration Equipment



HIGH PRESSURE  
BLAST GATES



HIGH PRESSURE  
ALTERNATING GATES

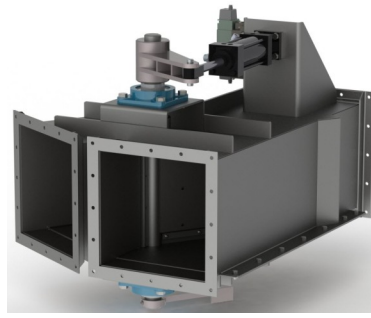

DIVERTER  
VALVES



BALANCING  
SLIDE GATES



CIRCULAR  
PULSE JET FILTERS



REVERSE AIR  
CLEANING FILTERS

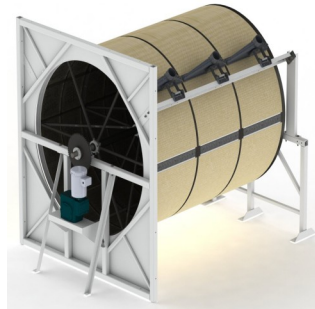

VACU-DRUM  
FILTERS

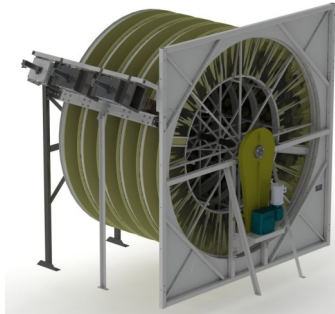

CIRCLE-VEE  
FILTERS



OVERHEAD OSCILLATING  
AIR CIRCULATION FANS



BAG  
FILTERS



PRE-SEPARATOR  
FILTERS

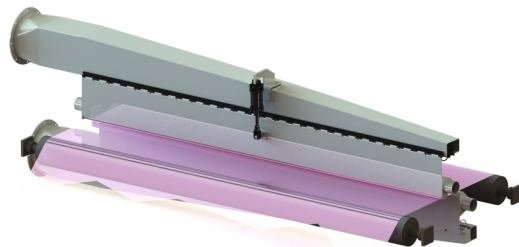

WEB CLEANING  
COLLECTION SYSTEMS

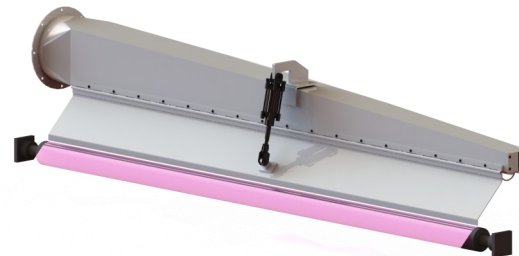

DUST COLLECTION  
HOODS

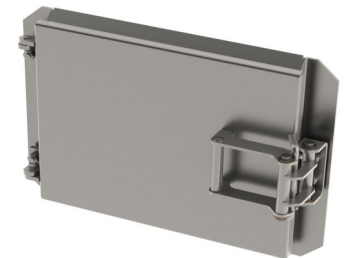

QUICK OPENING  
ACCESS DOORS

ATMOS360, Inc

64 Circle Freeway Dr

Cincinnati, OH 45246

Phone: (513) 330-5442