

Features:

- This direct ceiling mounted fan rotates at approximately four times an hour and
- oscillates vertically one time per minute distributing high velocity air over a large area.
- This high velocity air prevents the accumulation of dust and light debris on light fixtures, ceilings, support steel, overhead structures, ducts and machinery. Multiple fans can be arrayed to offer coverage for an entire production area.
- Designed for mounting to suitable existing beams or trusses.
- Available in a variety of
- different voltages, stem heights and reversing or non reversing styles.

Industries:

Textiles, paper, tobacco, wood, plastics, agricultural & rubber dust applications.

Available Services:

- System Integration
- Industrial Ventilation
- Material Handling
- Power & Controls
- Manufacturing

Product Description:

ATMOS360'S Overhead mounted fan rotates approximately four times an hour and oscillates (up & downwards) once per minute to distribute a high velocity airstream over a large area. This high velocity air prevents the accumulation of dust and light debris on support steel, lighting fixtures, ductwork, piping and other overhead structures.

Features and Benefits:

- Direct mounting to ceiling beams and trusses.
- Effective ~40 foot radius (12m) fan range.
- Adjustable up/down oscillation range.
- Adjustable rotation range (reversing models).
- Heavy duty powder coated steel construction w/polypropylene fan blade.
- Available with a standard or short mounting stem for low clearance applications.
- Designed to be mounted to suitable building beams or trusses.
- Bearings on pivot and oscillation points.
- Air flow = 3500cfm. (5950 m³ /hr)



OVERHEAD OSCILLATING FAN

ATMOS 360 Manufacturing, LLC.
4690 Interstate Drive, Suite A
Cincinnati, OH 45246
513.889.5069
ATMOS360.COM

Overhead Oscillating Fan Models

BASE FAN VOLTAGE/MODEL	MODEL #
115V NON-REVERSING	610111
115V REVERSING	610110
220V NON-REVERSING	610060
220V REVERSING	610062
400V NON-REVERSING	610101
400V REVERSING	610100
400V HIGH TEMP NON-REVERSING	610106
480V NON-REVERSING	610001
480V REVERSING	610061
480V HIGH TEMP NON-REVERSING	610071
575V NON-REVERSING	610090

STEM MODEL	MODEL #
STANDARD	610030
SHORT	610048

*When ordering, please specify both fan model number and stem model number required.

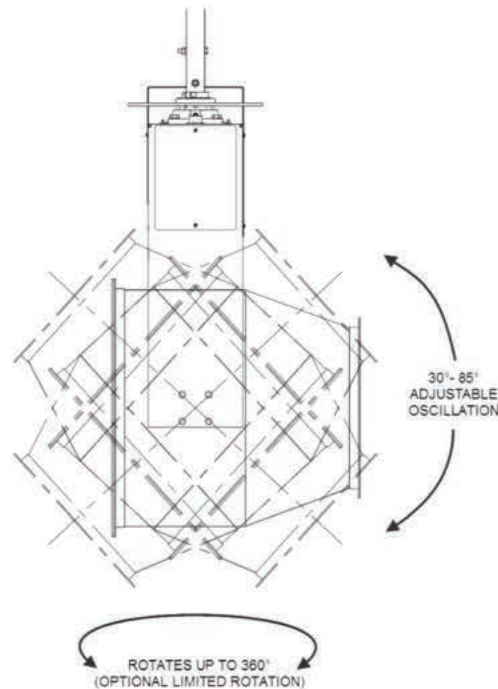
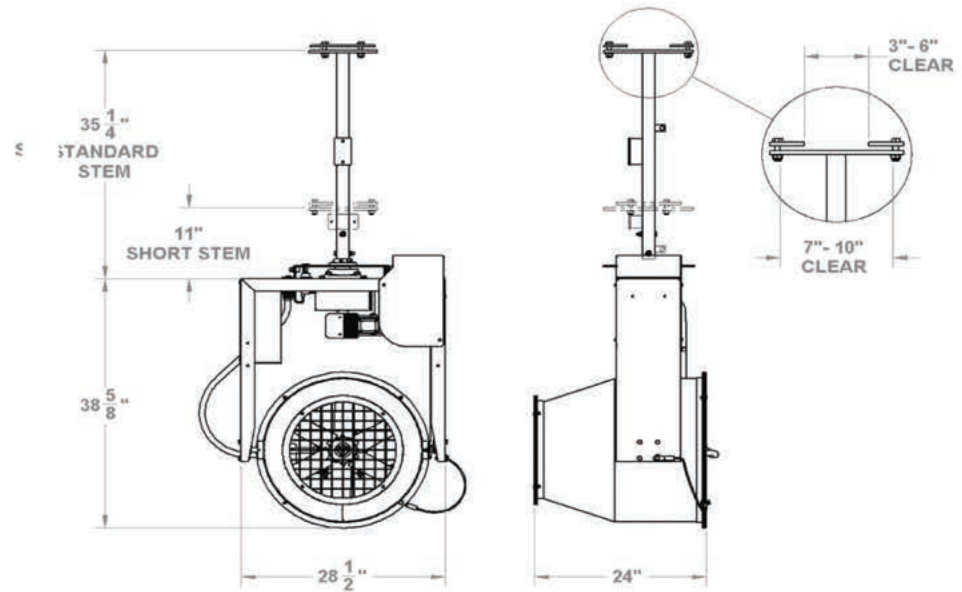

Replacement Parts

PART NUMBER	DESCRIPTION
906114	5/8" ID SLEEVE BEARING BRONZE
610007	PUSH ROAD ASSEMBLY
906110	4-BOLT FLANGE BEARING, 3/4" SHAFT

ATMOS 360 Manufacturing, LLC.
 4690 Interstate Drive, Suite A
 Cincinnati, OH 45246
 513.889.5069
 ATMOS360.COM

Standard Safety Features on all ATMOS 360 Overhead Oscillating Fans

Lanyards on all major components

- The fan housing is secured to the frame and the fan motor & blade assembly is secured to the housing. This will eliminate any major component from falling to the floor. We also put a mounting clip on the fan stem so that the stem can be secured to the ceiling. This lanyard is typically supplied by the installer due various mounting possibilities.

Safety hardware, castle nuts or nylon nuts

- All of the nuts used in the assembly of the fan are secured with nylocks or castle nuts. These nuts eliminate the possibility of the hardware getting loose or falling off the fan.

Inlet & Outlet Guards

- The inlet screen/guard will not allow items to be pulled into the fan causing the blades to be damaged. The outlet screen/guard keeps items from falling out of the fan if a part was to fail or break.

Double cross bolt on mounting stem

- The extra bolt used in the mounting stem is added insurance that the fan and stem will not come apart. The bolts are installed in a cross pattern for added safety as well. One bolt is more than adequate to hold the fan but the extra bolt is there as added safety.

Machined inner shaft with slip proof collar (this is the inner shaft that the stem mounts to)

- The mounting stem bolts to this inner collar. The inner collar is what holds the entire fan assembly to the stem. We designed the collar to have a machined lip or edge that keeps the bearing from ever slipping off the collar.

Here are a couple other notable features

- Each fan is tested before shipment.
- All steel components are powder coated.
- The powder coated finish just ensures a durable long lasting finish on the fan.
- All fans are crated in a specially designed crate with shock resistant feet.
- These specially designed crates keep the fan from getting damaged during shipment.

ATMOS 360 Manufacturing, LLC.
4690 Interstate Drive, Suite A
Cincinnati, OH 45246
513.889.5069
ATMOS360.COM

SAFETY FEATURES (STANDARD ON ALL MODELS)

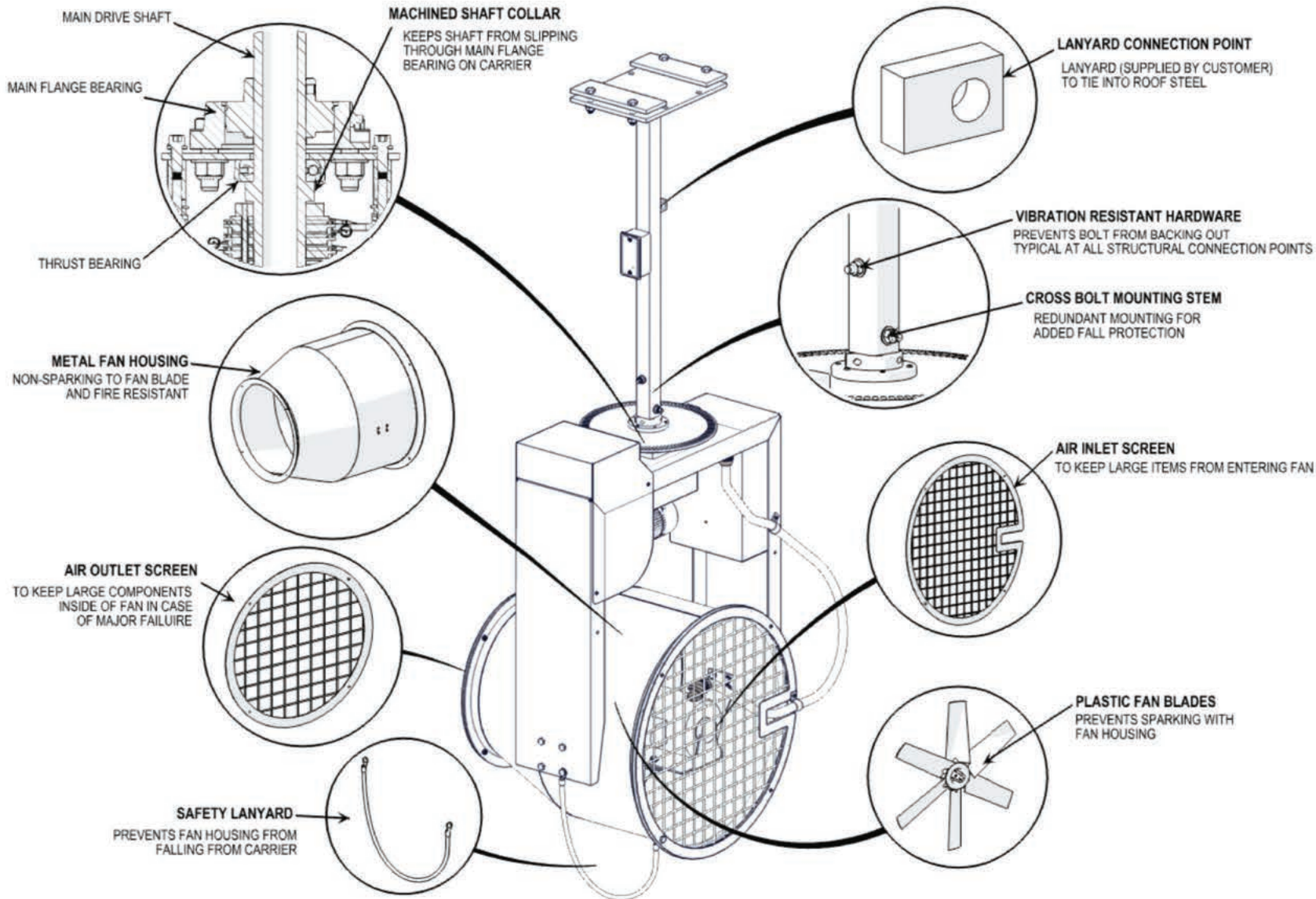

ATMOS 360 Manufacturing, LLC.
4690 Interstate Drive, Suite A
Cincinnati, OH 45246
513.889.5069
ATMOS360.COM